



The WAHI Inspector

Vol. XVIII, No. 2

February 2014

Editor: Nicholas Petrie

Upcoming Meetings

Central Wisconsin Chapter

Wednesday, February 19

Social 6 p.m., dinner/meeting 6:30 p.m.

Palms Supper Club Steak House

5912 Bus. Hwy 51, Schofield

Speaker: Project manager from affiliate member ABT Foundation Solutions, on basement water control and foundation repair.

Chippewa Valley Chapter

Wednesday, February 5

Dinner 5:30 p.m., meeting 6 p.m.

Jade Garden Restaurant

3620 Gateway Dr., Eau Claire

Speaker: Ben Campbell, City of Eau Claire building inspector, on egress windows, fire separation, and more!

Fox Valley Chapter

Tuesday, February 18

Roundtable 6 p.m., dinner 6:45, speaker 7:15

Stone Toad

1109 S. Oneida Street, Menasha

Speaker: Affiliate member Kevin Maynard on the inspection of log homes.

Madison Chapter

Thursday, February 20

Roundtable 6 p.m., dinner/meeting 6:30 p.m., speaker 7 p.m.

Rex's Inkeeper

301 N. Century Ave., Waunakee

Speaker: Sam Kessinich of Culligan Total Water, on inspecting water systems.

Milwaukee Chapter

Tuesday, February 11

Social 6 p.m., dinner 6:30 p.m., meeting 7 p.m.

Klemmer's Banquet Center

10401 W. Oklahoma Ave., West Allis

Speaker: Member Scott LeMarr of Milwaukee Mold Inspector, on attic mold.

From the President:

DSPS Education Audit Results



I recently went to a meeting at the Department of Safety and Professional Services (DSPS) with Kathy Kilgore, our lobbyist from Swandby/Kilgore. At this time the DSPS has not finalized any changes to the state regulations but I will tell you we are working with DSPS to assure any changes will not be detrimental to our organization.

Kathi did share the following results of the DSPS audit in an email, excerpted below:

Of the 693 licensees audited, 436 were not in compliance (37.1% compliance rate) for the following reasons, in order of prevalence:

- 134 licensees have not obtained 40 hours of continuing education since January 1, 2011. This also includes licensees who submitted an Audit Table without required certificates of completion; with insufficient documentation of course attendance; or submitted documentation for courses that do not relate to home inspection.
- 118 licensees did not complete 20 hours of continuing education in both 2011 and 2012, but did complete a total of 40 hours of

continued on p. 2

Ready, Set, Run... for WAHI office

Are you successful in your business? Do you want to add to that success? WAHI is the most professional association for inspectors in Wisconsin and the best in the country.

Those who volunteer to serve in a leadership role in WAHI include the top inspectors in the state. If you'd like to join them, don't sit at your computer thinking about volunteering or wondering if you're qualified to serve. WAHI needs you – on the state or your chapter level. See page 5 of this newsletter for details and important dates involving this year's state election.

You don't need 20 years of inspecting experience to contribute to WAHI, and working with WAHI will make you a better and more successful inspector. To learn more about running for office, contact Nomination and Elections Committee Chair Andy Helgeson at 262-377-0751 or ajhelgeson@wi.rr.com, or Executive Director Julie Arnstein at 877-399-WAHI or juliewahi@gmail.com.

President

continued from p. 1

- continuing education in the 2011-12 biennium.
- 81 licensees did not respond to the audit letters at all and/or did not submit any documentation of CE attendance.
 - 71 licensees did not complete 20 hours of continuing education in both 2011 and 2012 and did not complete 40 hours of continuing education in 2011-12, but completed continuing education hours in 2013 to apply retroactively to the 2011-12 biennium. These licensees have obtained a total of 40 hours of continuing education since January 1, 2011.
 - 31 licensees indicated they wanted to give up their licenses, had retired, or are deceased, and therefore did not complete 20 hours of continuing education in both 2011 and 2012.
 - One licensee who received a license in 2012, and therefore was only required to complete 20 hours of continuing education, did not complete 20 hours of continuing education in 2012, but had completed hours in 2011 prior to receiving his license. Therefore, this licensee completed a total of 20 hours of continuing education in 2011-12.

As you can see, the audit results are embarrassing to many inspectors. As a professional, I take pride in my licenses. I personally try to obtain a minimum of 40 hours every year. Sometimes the information is redundant but, no matter the subject or venue, I get to talk to other inspectors and learn something new every time. The one thing I know in this business is that if I ever think that I know or have seen everything, I will be wrong.

I just returned from the ASHI conference in Nashville, and learned a great deal. If you've never attended one of these large conferences, I strongly encourage you to do so. At the conference, I ran into several of the vendors who attended our December conference, and it was very interesting to listen to their feedback about WAHI and our educational events.

Almost every vendor I spoke with said the same thing. Over and over I heard that we at WAHI have the best conference, and the best-organized conference, of any they attend annually. They commented about the friendly and collegial atmosphere, the camaraderie between inspectors, the sharing of stories and helpful hints, and our excellent vendor cocktail party and hospitality room party afterwards. I must tell you that makes me proud to be a member and leader of WAHI.

And WAHI is still your best and most affordable option for your continuing education. Make a point to attend chapter meetings and our twice-annual seminar. You'll learn something new and have a chance to talk to your fellow inspectors and get your state-required credits, all at the same time.

We are holding elections at this time for many positions at the chapter and state level. If you have never been involved with running the duties of WAHI, I encourage you to run for a position. The responsibilities for many posts are minimal, and the personal rewards are tremendous. Most inspectors are sole proprietors, and working actively with WAHI provides many invaluable connections with others in our profession. The members who volunteer for these positions give their time and dedication to making WAHI the best home inspection organization in the country. The testimonials from our vendors prove that fact.

One last note: We could not find enough interest or attendees to hold the infrared training course I've been talking about. If you are interested, the Snell group does hold training around the country along with other companies. If you would like information on any of these trainers, please contact me and I can pass along more information to you.

Have a safe winter, get busy and think spring!
Mike von Gunten

Chapter Meeting Highlights



Our next meeting will be Wednesday, February 19th at Palms Supper Club Steak House, 5912 Bus. Hwy 51 in Schofield. Social hour begins at 6 p.m. and dinner at 6:30 p.m. The cost to attend a monthly chapter meeting is \$25 with dinner or \$10 without the meal. Contact Rich Duerkop with any questions at 715-241-8222 or e-mail americansentry1@charter.net. Our speaker will be the project manager from affiliate member ABT Foundation Solutions, specialists in basement water control and structural foundation repair.



At our January meeting, Dan Green from Water Source discussed the full range of geothermal system types, how they function, and how to evaluate their condition and operation.

Our next regular meeting will be Wednesday, February 5th at Jade Garden Restaurant, 3620 Gateway Dr., Eau Claire. The buffet supper starts at 5:30 p.m., followed by our meeting at 6 p.m. The cost of supper and meeting is \$20 (tip extra). The speaker will be Ben Campbell. Ben is a City of Eau Claire building inspector and will be discussing egress windows, fire separation, and other related topics. We encourage members to bring any photos to present.

The chapter normally meets on the first Wednesday of each month. Due to production dates, members may not receive a newsletter issue until very close to our meeting date, or even after. To avoid missing a meeting, please mark your calendar in advance.



The next meeting will be Tuesday, February 18th at the Stone Toad, 1109 S. Oneida Street in Menasha. Cocktails and roundtable discussion start at 6 p.m., 6:45 dinner, 7:15 speaker, meeting to follow. The speaker will be affiliate member Kevin Maynard, regarding the inspection of log homes.

continued on p. 4

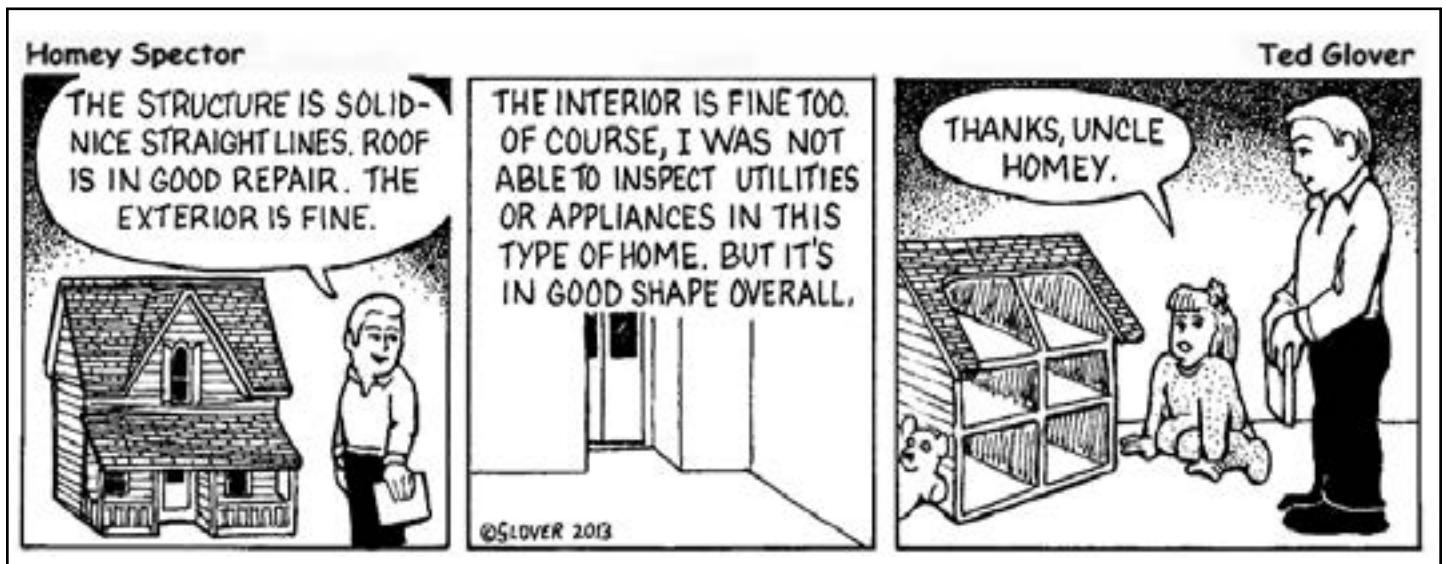



The Madison group had a good turn out for a cold January night. President Dennis Kruger instructed the group on proper reporting and record keeping of continuing education credits. We discussed the need to keep WAHI's training on a professional level. Adding to the discussion was how to report items such as knob and tube wiring or asbestos. Discussion was held as to how to deal with clients who want us to write up "code" violations when we are not "code" inspectors. Wording on reports was discussed so we could cover ourselves but still follow State rules.

The Madison chapter meets six times per year on the 3rd Thursday in January, February, May, June, September and October. Our next meeting will be on Thursday, February 20th at Rex's Inkeeper, 301 N. Century Ave., Waunakee. Roundtable begins at 6 p.m., dinner/meeting at 6:30 p.m. and speaker at 7 p.m. The speaker will be Sam Kessinich from Culligan Total Water, who will discuss water systems and inspection procedures.



Our next meeting will be Tuesday, February 11th at Klemmer's Banquet Center, 104th & Oklahoma Ave. in West Allis. Social at 6 p.m., dinner at 6:30 p.m., meeting at 7 p.m. Cost is \$25, which includes dinner and the continuing education. The speaker will be longtime home inspector member (Honest Home Inspections LLC) and now new affiliate member, Scott LeMarr of Milwaukee Mold Inspector. Scott will present Attic Mold: Causes, Solutions and Health Concerns.

ABT

We Fix Bad Basements...RIGHT!
Call 800-967-4ABT (4228)

Foundation Solutions, Inc.

Foundation Problems? Wet Basement?

Foundation and Basement Repair Experts
 Covering Northeast and Southwest Wisconsin

- Bowed Walls
- Foundation Settlement
- Basement Wall Cracks
- Water Problems
- Damp Crawl Space
- Egress Windows

We follow WAFRP standards

Free Estimates • Financing Available • Transferrable Warranty

www.CALLABT.com • 800-967-4ABT (4228)

Fox Valley 920-733-4228 • Green Bay 920-435-4228 • Madison 608-350-1111

State Election 2014

The WAHI State Election is upon us. All members are asked to consider serving in a position of leadership in the coming year at either the chapter or state level.

The membership will be electing the state President and Vice President – both to two-year terms. The election will be held in early March and the results announced at the Annual Meeting on March 15, 2014. Nominations and Elections Chair Andy Helgeson will be accepting nominations in January and February 2014. If you are interested in a position or would like to submit a nomination, please contact Andy at 262-377-0751 or ajhelgeson@wi.rr.com.

This election will be held electronically. Members without email access will receive a paper

ballot by U.S. mail as in the past – same deadline dates will apply.

Election Deadline Dates

- Friday, February 21st
Nominations Deadline: Please contact Nominations and Elections Chair Andy Helgeson to submit nominations.
- Saturday, March 1st
Bio Deadline: All nominees are asked to provide a brief bio to include with the ballots. Julie Arnstein will contact all nominees regarding the bio request.
- Monday, March 10th
Voting Deadline: Vote must be cast by this date to be included in the ballot tally, or post-marked for those submitting a paper ballot.

We Solve Drainage Problems

Do You Have....

- Basement walls with mold, cracks or are buckled?
- Water seeping into the basement?
- Poor grading that slopes toward the house?
- A continually wet yard?
- Cracked or heaved concrete?

Call NOW to prevent more damage !!

262-255-7882



Wandsnider Landscape Architects

Since
1977

Menomonee Falls, WI



- Landscape Design and Construction
- Drainage Solutions
- Bill's Contractor Storage

www.wandsnider.com

Mystery Photo



This month, a Milwaukee Chapter inspector sent us this photo of a water heater. The inspector wrote, “I’ve never seen this type of water heater before. What can you tell me about this type of heater?”

Doug Hoerth, WAHI Vice-President replies:
The heater appears to be natural draft direct vent, but the exhaust is sealed at the top, and it vents out through the sidewall of the home. Not to be confused with a power-vented heater, this heater has no fan. The pipe on top is a double-walled pipe. The outer section of the pipe supplies outside air for combustion to the combustion chamber. The inner part of the pipe is the exhaust vent. Sometimes this is flexible metal as well. But note that flue clearances to combustibles still do apply, the flues must be sealed, and obviously the gas line is problematic.

This type of direct vent heater is often used in mobile homes, although the pipe tends to vent straight up through the roof. Also less often in small basements or utility rooms when there is not enough makeup air for combustion, or when the chimney is damaged or not available. The nice thing about this system is that it can be vented through the sidewall and terminate 12” above grade.

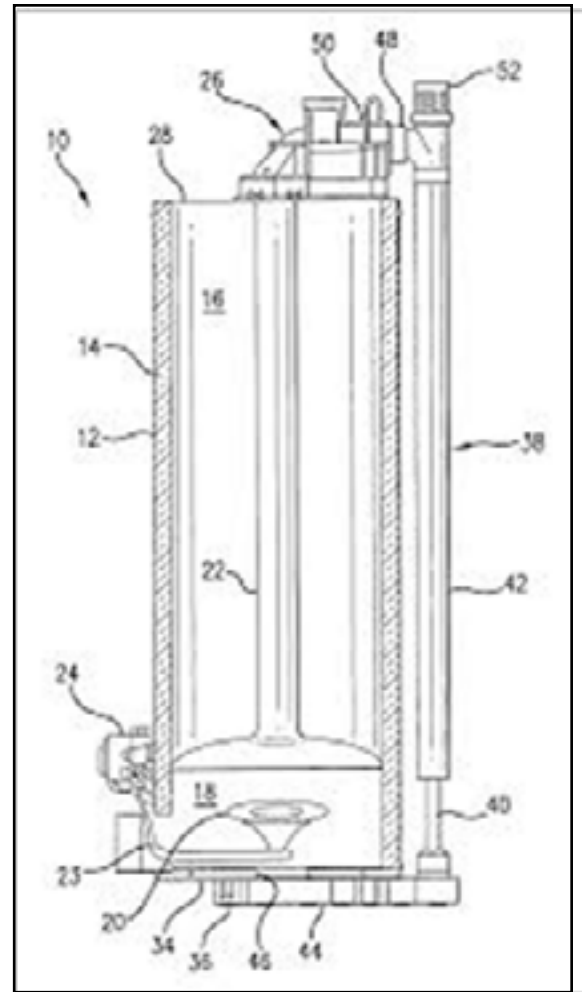

Nick Petrie, newsletter editor adds:
I spoke to Larry Budiak of Budiak Plumbing about this water heater. He said this type was more popular in the eighties, before manufacturer-designed power-vent heaters were made. He almost never sees them any more, but he believes they are still allowed under Wisconsin code. As an alternative in the future, the homeowner could add a grate in the basement door or ceiling to provide makeup air for a power-vented water heater.

We’re hoping this article is the first in a series featuring unusual items found at inspections. Of course, we need our readers to send us photos with a description of the item to make this work. We need your help to improve your newsletter! Send mystery photos to Nick at smartmove@wi.rr.com.

WAHI has a Facebook Page



WAHI invites you to join us on Facebook. The WAHI Facebook page is a wonderful venue to make chapter announcements (meeting changes, speakers, location updates, meeting reminders, etc.), board announcements, post State Board meeting minutes, etc.

Please see below for instructions on creating a Facebook account if you do not have one yet, and how to find the WAHI page

How do I sign up for Facebook Account?

To create an account, go to www.facebook.com. Enter your name, birthday, gender and email address. Then create a password. After you complete the registration form, Facebook will send you an email. Just click the confirmation link to complete the sign up process.

How do I find the WAHI page?

After you have created your Facebook page, type Wisconsin Association of Home Inspectors in the search box. Request to be "liked." You will get a response when WAHI accepts the request. The WAHI Facebook page is a closed

group – only WAHI members can view and participate on the page.

Any questions? Contact Bob Turicik at homereview@wi.rr.com or 920-892-7654.



Services



- ◇ Water damage assessments*
- ◇ Fungal (mold) analysis & testing*
- ◇ Asbestos testing
- ◇ Allergen & chemical sampling
- ◇ Industrial hygiene

* Results provided immediately on-site

Come join us in the hospitality suite during the WAHI convention and enjoy complimentary test tube shots & microbrews at our BIOBar.

Environmental Initiatives LLC
(414) 651-6453 | (608) 790-2665 | (847) 293-7554 | (920) 253-1247
Toll Free: (877) OK-ENVIRO (653-6847)
www.enviroinit.com

Comprehensive inspection reports, made easy.

InspectIT® is one of the most advanced home inspection software products on the market today, utilizing a cloud-based environment for flexible access and maximum security. Designed by industry professionals, this home inspection software will help make your job easier and your business more successful.



With InspectIT, you can:

- Access, modify, & create your reports, contacts, & quotations from anywhere, on any device.
- Create reports that match your business.
- Be confident that your data remains safe & secure.
- Receive free, automatic software updates.
- Enjoy free, unlimited support.
- Work on any PC or Android device.



Call 877.211.7483

to learn more or to schedule a free demonstration,
or visit www.inspectit.com



17425 Gebhardt Rd.
 Brookfield, WI 53045
 Office: (262) 797-8181
 Cell: (414) 588-5800
 www.smokestacks.net



I come across this violation often, so I thought I would forward the code for you to read.

Wisconsin Administrative Code SPS 321.29

Masonry Fireplaces (11) Mantel shelves and combustible trim

Woodwork or other combustible materials shall not be placed within 6 inches of the fireplace opening. Combustible materials located within 12 inches of the fireplace opening shall not project perpendicularly more than 1/8 inch for each inch distance from the opening.



Providing the best protection at the best price.

The InspectorPRO insurance program has been specifically designed for property inspectors. By providing insurance solely to inspectors, InspectorPRO helps members achieve substantial savings on their E&O insurance.

General & Professional Liability

Coverage Limits Available:

- \$2,000,000
- \$1,000,000
- \$500,000
- \$300,000
- \$100,000

Deductibles:

- \$250 General Liability
- \$1,500, \$2,500, or \$5,000 Errors & Omissions

General and Professional Liability are both written by the same carrier.

There are no sublimits on any of our endorsements.

HIGHLIGHTS

1. Policy covers both E&O and GL
2. Retro-Active coverage included (proof of retro required)
3. Reator and Referring Party Indemnification included
4. Multi-inspector coverage available on one policy
5. Residential and Commercial inspection coverage included standard
6. There are endorsements for the following:
Mold, Water Testing and Septic, Pool and Spa, Radon, Termite/Pest/WDI And More!
7. Energy Audits, Infrared, 203K Inspections, etc. Included
8. Diminishing Deductible
9. Aggressive Claims Process
10. Financing Available

Call or Go Online Today to Apply

phone: 801.610.2735
 www.InspectorPROinsurance.com

You Deserve the Best Home Inspector's E&O Insurance

Minimum Insurance Premium: \$1,250**

Are you paying extra for "add on" coverages, or worse, going without full coverage to save money? No need to pay more or go without full coverage any longer! Broad coverage included in minimum premium.

Includes General Liability*/Premises Coverage (Bodily Injury & Property Damage while on site), and most incidental coverages, such as termite, radon, commercial. (* Ask OREP agent.)

- "A" Rated Carrier, Prior Acts, Additional Insured for Agents and other Referring Parties
- Convenient: Fast, Self-Rating Application gets you quoted and back to work in minutes.
- No Policy fees, no Taxes
- Includes discounts on ASHI/NAHI/state-approved education & training, access to group medical coverage (Calif) and more.

** \$1,250 Coverage Limit is for \$300,000 Aggregate/
\$100,000 each Occurrence.
Choice of coverage limits and deductibles
available.

Find details at www.OREP.org

OREP
(888) 347-5273

6760 University Ave. #250 • San Diego, CA 92115 • Fax: (760) 570-5786 • info@orep.org • David Brauner: Calif. Insurance Lic. #0C89873



Basement
REPAIR SPECIALISTS

Free Estimates • Quick Turnaround • Great Prices

WAFRP & WAHI member • Site Specific Engineering Available

SERVICES:

- Water Control
- Wall Repair & Replacement
- Deep Foundation Work (Piers)
- Egress Windows

Now Serving All Of Wisconsin!

855-554-RAIN (7246)

855-554-PIER (7437)

www.basementrepairspecialists.com

Licensed & Insured

*"We are very thankful to Basement Repair Specialists for their extra effort to complete the installation in such a timely manner to meet our house closing timetable."
Pat R. ~ Weyauwega*

Where to Find E&O Insurance for Inspectors

Allen Insurance Group

P.O. Box 1439
Fort Valley, GA 31030
Contact: Bob Person (ext. 172),
Melissa or Heather (ext. 175)
1-800-474-4472
Great service, many choices and fee schedules.
Covers radon also.

Citadel Insurance Services, LLC

826 E. State Road, #100
American Fork, UT 84003
Contact: Jason Fiack
801-610-2735; Fax 801-610-2701
www.inspectorproinsurance.com
General liability and errors & omissions
insurance for home and building inspectors

FREA

4907 Morena Blvd., #1415
San Diego, CA 92117
800-882-4410 or www.frea.com
Offers competitive rates, a low deductible
and a package of other benefits. Rates for
commercial and residential inspections; not
based on volume or revenue.

OREP

6760 University Ave. #250
San Diego, CA 92115
888-347-5273; Fax: 619-704-0567
info@orep.org
www.orep.org
Includes premises coverage & most incidental
coverages. Competitive rates.

Vincent, Urban, Walker and Assoc. Inc.

139 S. Washington St.
P.O. Box 8608
Green Bay, WI 54308
Contact: Debbie Catsuros at 920-432-7246
Many types & companies. Services individual
inspectors; fee based on volume. Radon also.

Zolofra Insurance Agency

P.O. Box 8787
Red Bank, NJ 07701
Contact Ben Zolofra at 888-858-1777 or
ben@zolofrainsurance.com
www.allprocoverage.com
Multiple carriers. Coverage on mold and lead
testing, septic, pest & pool inspections, prior
acts, workers comp, commercial auto, more.



HomeGauge
Now with video.

Get a FREE 30-day trial of our
home inspection software at
www.HomeGauge.com.

Call for more information:
877-274-4299

Windows | Android

Important Notice

Chapter Meeting Continuing Education Credits

By now, all Home Inspector and Associate Members should have received a postcard indicating their continuing education credits earned in 2013 from attendance at monthly WAHI chapter meetings. Please put this postcard in a folder marked Continuing Education Credits 2013. Be prepared! Contact Julie Arnstein *immediately* if your records indicate something different in terms of meeting attendance and earned credit.

Changes are bound to happen at the Department of Safety and Professional Services in Madison as a result of the state audit. WAHI plans to be ready and encourages the membership to do the same.

The Fox Valley WAHI Chapter recently implemented a program using an Attendance Verification Form (AVF). At the chapter meeting, each attendee completes a form with their information as well as the details

of the evening's educational program. At the conclusion of the meeting attendees are given a password, specific to that meeting. This password is intended to verify that the attendee did not leave the meeting early and truly earned the full credit count. The form is in duplicate – one copy to be kept by the attendee and the other for the chapter records. Starting January 2014 all WAHI chapters will make use of this form and implement this procedure.

After January 2014 WAHI will no longer notify members of their year-long chapter meeting attendance credits at the end of each year. Members will be responsible for maintaining their own record of earned Continuing Education Credits with their copy of the Attendance Verification Form. Members are encouraged to have a folder marked Continuing Education Credits 2014 for their AVFs as well as seminar certificates.

Help your customers. Build your business.

Give your customers a perfect guide to home maintenance and repair – and differentiate yourself from the competition! Along with your quality report, provide a copy of this great book with your contact information added. They'll keep it handy, and your name will be on display indefinitely. If you are a new customer, you can purchase your first case of 22 books at \$7.50 per book.

Visit our website at www.htoyh.com to see all of our books and other marketing products that can give your business a boost.

*"Your book and newsletter are my only marketing tools. I never depend on Realtors, and I am a very busy home inspector."
–Kirk, Wisconsin*

www.htoyh.com
(800) 201-3829



**HOW TO OPERATE
YOUR HOME**

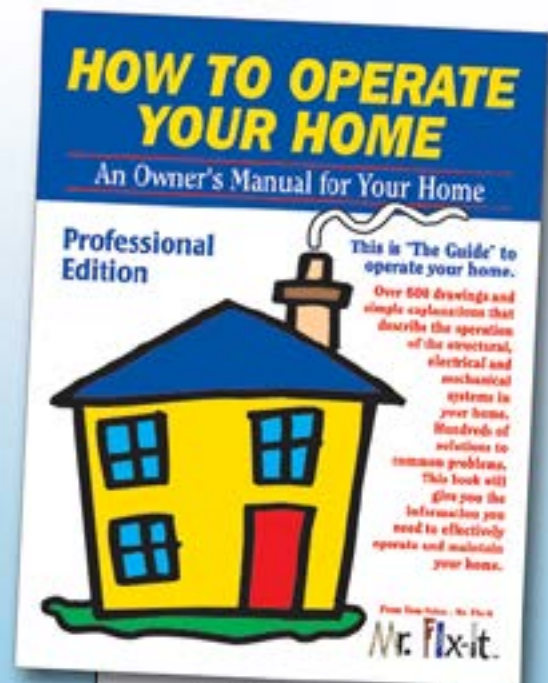

List \$29.95
Your cost as low as \$6.50



Zolofra Insurance Agency

P.O. Box 8787 Red Bank, New Jersey 07701
Phone 888.858.1777 Fax 732.334.0405
www.allprocoverage.com

HOME INSPECTORS INSURANCE

WHY USE US?

- It starts with service – we are here to pick up your call!
- Access to multiple insurance carriers.
- Over 17 years experience. We know the markets and coverages!
- Coverage available also for Mold Testing, Lead Testing, Septic Inspections, Pool/Spa Inspections, Radon, Termites, 203k inspections, construction draw inspections, prior acts and more!
- Low deductibles in case you have a claim. High limits available as well.
- New inspectors, veteran inspectors, with claims or no claims.
- We can also provide you insurance for Workers Compensation, Commercial Auto, etc.
- We are a Trusted Choice Independent Insurance Agency.

WHY PURCHASE E&O INSURANCE?

- Claims against home inspectors increase every year, whether the market is good or bad, even if you have done everything correctly on your inspections. E&O Insurance will defend you against your toughest clients.

HOW MUCH WILL IT COST?

The annual cost of a base policy is \$1,100.00 (includes all taxes and fees).

TO FIRM UP A QUOTE:

Please take a minute to complete your online application at:
<http://www.allprocoverage.com/inspectors-contact-form/>



Trusted Choice™ agencies are insurance and financial service firms whose access to multiple companies and commitment to quality service enable us to offer our clients competitive pricing, a broad choice of products and unparalleled advocacy

888.858.1777

www.allprocoverage.com

ben@zolofrainsurance.com

Tips and Tidbits

Infrared Training

Due to low turnout the Level One Thermal Imaging Course scheduled for February 4-7 in Baraboo was cancelled. Stay tuned for information regarding another training opportunity – a 2-day course specifically geared to home inspectors. More information will be shared at the spring seminar at Ho-Chunk, March 14th and 15th.

State Board Meeting

The next WAHI Board of Directors meeting will be Friday, March 14 at 2:30 p.m. This meeting will be held in conjunction with the Spring 2014 Training Seminar at Ho-Chunk Casino and Conference Center in Baraboo. If you would like to attend, contact Julie Arnstein at juliewahi@gmail.com or 877-399-WAHI by Monday, March 10th.

Annual Meeting

The 13th Annual Meeting will be held in conjunction with the WAHI Spring 2014 Training Seminar at Ho-Chunk Casino and Conference Center, during lunch. Members not attending the Seminar but interested in attending the Annual Meeting should contact Julie Arnstein by Monday, March 3rd to ensure sufficient seating in the room.

WAHI Spring 2014 Training Seminar

We hope you have marked your calendars for the WAHI Spring 2014 Education House and Training Seminar on Friday, March 14th and Saturday, March 15th in Baraboo at the Ho-Chunk Casino and Conference Center. We will again offer training at a WAHI Education House on Friday, followed by our great cocktail party in the Vendor Room that evening from 7-9 p.m. and classroom training all day on Saturday. Look for the the Seminar registration form on pages 16-17 of this newsletter. Hope to see you in Baraboo!

WAHI Legal Support (WLS)

Attorney Roy Wagner, of von Briesen and Roper, continues offer risk-free initial counseling to members with legal concerns. If further legal assistance is requested, the cost of the initial consultation will be included in the bill. Contact Roy at 414-287-1250 or rwagner@vonbriesen.com. Note: The WLS program is completely independent of the WAHI Arbitration System.

2013-2014 WAHI Membership Roster

The 2013-2014 membership roster is now on the website and available for viewing and/or printing. All members are encouraged to check their listing. It reflects the information that WAHI has on file for you. Please submit updates/corrections to Julie Arnstein at juliewahi@gmail.com or info@wahigroup.com

Ride Along Program

The WAHI Ride Along Program assists new members as they embark on their business.

continued on p. 14

The WAHI Inspector is the official publication of the Wisconsin Association of Home Inspectors. Published monthly, deadlines are the 20th of the month before publication (ie. May 20th for the June issue).

Wisconsin Association
of Home Inspectors, Inc.
c/o 4590 S. Raven Lane
New Berlin, WI 53151

414-299-9766 (Milwaukee)
877-399-9244 (Toll-free)
262-785-6765 (Fax)

www.wahigroup.com

Executive Director: Julie Arnstein
juliewahi@gmail.com

Tips and Tidbits

continued from p. 13

Experienced members interested in sharing their knowledge and experience with a fellow member by allowing them to accompany you on an inspection are asked to contact Julie Arnstein. Julie will add their name to a list given to a member looking for guidance of this type. Contact Julie at 414-299-9766 or 877-399-WAHI or juliewahi@gmail.com.

WAHI Arbitration Program

All members are encouraged to make every effort to resolve homeowner/inspector disputes without outside help. When that is not successful, know that the WAHI Dispute Resolution Program is there for you. The process begins when the complainant (homeowner) contacts Resolute Systems, the program administrator, via mail at 1550 N. Prospect Ave., Milwaukee 53202, e-mail at info@ResoluteSystems.com or their Web site at www.resolutesystems.com.

For information contact Arbitration Committee Chair Dave Strandberg at 608-255-3966 or dstrand8@tds.net.

Office Max Discount

The Office Max corporate discount is available to all members of WAHI. Purchase online at www.OfficeMaxSolutions.com. The user name is wahi and the password is member1. In-store purchases require use of a WAHI Retail Connect Card. See the November 2012 issue (page 16) of the newsletter at www.wahigroup.com for a printable card. Office Max will laminate the card when you visit the store.

We Need Your Current Email Address!

Via our website, WAHI sends mass emails containing important announcements and interesting articles/information. Having your correct email address is vital in terms of WAHI

communication. Take a look at your listing in the member database on the website and let us know if your info is not up-to-date.

New Email Address for WAHI Executive Director

Please update your email address book for Julie Arnstein. Effective immediately her new address is juliewahi@gmail.com.

Member News

Share your news, joys, recognitions, temporary setbacks (illness or injury), etc. Privacy should be recognized, and information provided must be okayed by the person involved. Send submissions to Julie at juliewahi@wi.rr.com. Deadline is the 20th of the month before the newsletter (ie. March 20th for the April issue).

Updating Your Contact Info

Please visit www.wahigroup.com and find your listing under the members tab on the home page. If you have recently moved or if your information is not correct/complete, please contact Julie at info@wahigroup.com, 877-399-WAHI or fax at 262-785-6765. Updates are listed every month in the WAHI Inspector.

Special Spaces

Andrew Risch, longtime Milwaukee Chapter member and architectural designer for Embassy Homes, is involved with a valuable program. Special Spaces is a non-profit organization that creates dream bedrooms for children with life threatening illnesses. To make this program a success they are seeking volunteers. For information, contact Andrew at 262-241-8510, x111 or Andrew@emabassyhomes.com. You may also be interested in visiting www.specialspacesmilwaukee.org.

continued on p. 15

Tips and Tidbits

continued from p. 14

Chapter Secretaries

Chapter Secretaries are reminded to include upcoming speaker and topic information when submitting monthly meeting minutes to Julie Arnstein. The information will be included in the newsletter and will also be posted on our Web site at www.wahigroup.com.

Add a Photo to the WAHI Web Site & Link to Your Site

WAHI's Web site is up and running – as well as the new member database with a new and improved multi-choice search option. Submit photo and/or company web addresses to info@wahigroup.com.

Communication

All member-to-member or member-to-association disputes must go through the Membership Committee. A member going public with a member or association dispute will be grounds for disciplinary action. The Membership Committee will implement this policy. Contact Committee co-chairs Doug Hoerth (920-375-0723 or finallookinspectionservices@yahoo.com) or Glenn Schmidt (920-923-0440 or gcschmidt1@att.net).

Chapter Presidents

Please give your WAHI Board Member-at-Large an opportunity to share information from recent Board meetings. They are the liaison between your chapter and the WAHI Board.

Board of Directors

President Mike Von Gunten (262) 945-2446	David Strandburg (608) 255-3966
Vice President Doug Hoerth (920) 375-0723	Kyle Zimmermann (715) 387-1815
Secretary Julie Arnstein (877) 399-9244	Executive Director Julie Arnstein (877) 399-9244
Treasurer Tom Greenwaldt (262) 547-3678	Central Wisc. Chapter Rich Duerkop, President (715) 241-8222
Members-at-Large Troy Beasley (414) 737-2721	Chippewa Valley Chapter Dave Waraxa, President (608) 534-7709
Dennis Kruger (608) 835-5395	Fox Valley Chapter Kent Schwanke (800) 585-4708
Ron Miller (608) 832-6630	Madison Chapter Dennis Kruger, President (608) 835-5395
Brian Opelt (715) 937-2002	Milwaukee Chapter Scot McLean, President (414) 228-6573
Nick Petrie (414) 961-1400	
Dave Pribyl (920-660-3000)	
Kent Schwanke (800) 585-4708	

Statewide WAHI Committees

Affiliates <i>See Membership Committee</i>	Membership Doug Hoerth, Co-Chair Glenn Schmidt, Co-Chair Paul Birschbach • Roger Kautz Jerry Schneider
Arbitration David Strandberg, Chair Roy Wagner	Nominations/Elections Andy Helgeson, Chair Rich Duerkop • Dennis Kruger Cassidy Kuchenbecker Scot McLean Kent Schwanke • Dave Waraxa
Audit Tom Greenwaldt, Chair George Finch • Roger Howard Scott Jarvis • Joe Perlock Dave Stoinski	Public Relations Bob Turicik, Chair Troy Beasley • Bruce Low Nick Petrie • Chuck Weber
Clearinghouse (subcommittee of Legislative) Inactive	Rules & Bylaws Andy Helgeson, Chair Erick Beck • Tom Dempsey Tom Greenwaldt
Education Tom Kruse, Co-Chair Kent Schwanke, , Co-Chair John Moore • Pete Saltness	WAHI Legal Support (WLS) Chair position is vacant Ron Miller • Roy Wagner
Education House Kent Schwanke, Chair	Web Site Doug Hoerth, Chair Keith Vanevenhoven
Legislative Ron Miller, Chair	

Wisconsin Association of Home Inspectors, Inc. (WAHI™)

Spring 2014 Training Seminar - 15 Credits

Friday March 14 and Saturday March 15, 2014

Ho-Chunk Casino and Conference Center

S3214 Cty Road B-D (formerly Hwy 12), Baraboo, WI 53913

Friday March 14th (up to 7 credits)

Education House - Review & Training

7:30 am Registration
8:00 am **Inspection Review Begins**
12:00 pm Inspection Review Concludes
Break for Lunch
1:00 pm **Inspection Training Begins**
5:00 pm Inspection Training Concludes
Distribution of CEU Certificates
Event details and registration form (over)
7 - 9 pm Vendor Room Cocktail Party (Ho-Chunk)
Appetizers and Door Prizes too!

Saturday March 15th (8 credits)

7 - 8 am Registration and Breakfast
8:00 am **Weatherization**
Adrian Scott, WI Energy Conservation Corp.
9:45 am Break and Visit the Vendors
10:15 am **Solar Power - Residential Use**
Keith Ouimette, Cardinal Htg and AC, Inc.
12:00 pm Lunch/Annual Meeting/Visit the Vendors
1:30 pm **Radon - Causes, Testing and Mitigation**
Tom Heine, Radon Abatement Inc.
3:15 pm Break and Visit the Vendors
3:45 pm **Geo Thermal Heat Pump Systems**
Dan Green, Water Source of Eau Claire
5:30 pm Distribution of CEU Certificates

Friday March 14th, 7-9 pm Cocktail Party in the Vendor Room!

Continuing Education Credit

This seminar is approved for up to 15 continuing education credits with the State of WI,
Up to 14 with ASHI and NAHI

Location: Ho-Chunk Casino, S3214 Hwy 12, Baraboo, WI

To reserve a room, call 1-800-746-2486. A block of rooms is being held for March 13, March 14 and March 15 at a rate of \$89.00. Be sure to mention "2167" when making your reservation.

Room block expires on Thursday February 27, 2014

-----Please Submit Saturday Registration Form-----

Name and Company Name _____
Address _____
City _____ State _____ Zip _____
Phone _____ Email _____

Make checks payable to: WAHI

MasterCard or Visa: _____ **Exp:** ____/____

Circle Your Registration Fee: (Friday Registration Form/Fees on back)

	By Feb. 20th	After Feb. 20th	On Site	Return this form, with payment, to:
Saturday	\$145	\$175	\$205	WAHI, c/o Julie Arnstein
Friday & Saturday (\$50 savings!)	\$230	\$260	\$290	4590 S. Raven Lane.
Non-Members add \$30.00 to fees stated				New Berlin, WI 53151

Fee includes Saturday Breakfast, Breaks & Lunch.

Fax (262) 785-6765

Email: juliewahi@gmail.com

Questions: (877) 399-WAHI

- I plan to attend the training on Friday March 14th (Complete form on other side)
 I plan to attend the Friday Cocktail Party, 7- 9 pm in the Vendor Room
 I plan to bring a guest on Friday night

**Education House
Peer Review and Training
Friday March 14, 2014**

This on-site inspection event is comprised of 2 parts - an inspection *review* in the morning, followed by inspection *training* in the afternoon. WAHI has obtained the use of a home in the Baraboo area for this program.

Inspection Review

This inspection review event is an opportunity for you to evaluate and refine your inspection skills with the aid of a panel of your peers, rather than a person with a black robe and a big “hammer” (i.e. gavel). Results will be kept strictly confidential.

The inspections will begin at 8:00 AM. Participants will have two hours to complete their inspection (electrical panels will already be removed, ladders in place, cover off the furnace, etc. to aid in the time limit) Upon completion participants will immediately present their findings and their completed report to the panel as if to a client - the panel of judges have inspected the house and identified defects. Participants are required to bring 2 additional inspection reports (recently completed) for review by the panel to access if they are meeting state standards. There will be “must find, must report” items, previously identified by the review panel, the panel will be looking for (the panel will be focusing on the identification of major defects, not issues such as windows or doors sticking). During the inspection process communication between participants will not be allowed - this event is intended to help participants evaluate their personal skill level. The morning session will be worth 3 continuing education credits and is limited to the first 10 registrants.

Inspection Training

The afternoon session will be inspection training at the same property. Experienced inspectors and contractors will be posted throughout the house in numerous locations to provide approximately 45 minute presentations on how to inspect various components - participants will then rotate to the next area/presenter. The training will take place from 1:00 pm to 5:00 pm and will be worth 4 continuing education credits. The afternoon portion will be limited to the first 40 registrants.

WAHI Member cost to attend this event is as follows:

Educational Review (morning) - \$75.00 Inspection Training (afternoon) - \$60.00

Review **and** Training (all day) - \$135.00

Non-Members add \$30.00 to the fees stated.

All participants must preregister as space is limited – no on-site registrations.

All participants will be notified by a member of the Education House Committee with the specific location.

Lunch (pizza) from 12:00 pm to 1:00 pm for the morning and all day participants.

For further information contact: Kent Schwanke at (920) 229 -7854 or secondlook@charter.net

-----Please Submit **Friday** Registration Form-----

Name and Company Name _____
Address _____
City _____ State _____ Zip _____
Phone _____ Email _____

- I plan to attend the Educational Review Only (Morning) - \$75.00
 - I plan to attend the Inspection Training Only (Afternoon) - \$60.00
 - I plan to attend all day - Review **and** Training - \$135.00
- Non-members add \$30.00 to fees stated

Return this form, with payment, to:
WAHI, c/o Julie Arnstein
4590 S. Raven Lane.
New Berlin, WI 53151

Make checks in the appropriate amount payable to: WAHI
MasterCard or Visa: _____
Exp: ____/____

Fax (262) 785-6765
Email: juliewahi@gmail.com
Questions? (877) 399-WAHI